

Panel-PC-17-A

17" Android Panel PC (4:3) incl. Automation Browser



Panel-PC-17-A is a 17" industrial panel pc with a capacitive 4:3 TFT LCD touchscreen, 1280 x 1024 pixels and pre-installed Automation Browser. Power Supply 24V DC.

The 17" Web Panel has the pre-installed Automation Browser and is designed for connection to controllers with their own web server (e.g. CODESYS V3 web server). Setup and operation of the web browser are extremely simple and intuitive. The integrated WiFi and Bluetooth interfaces enable the most diverse uses. The housings are designed in IP65 at the front and have a very compact and robust design due to the aluminum housing. The projected capacitive touch enables multi-touch operation. The 24V DC Panel-PC series is based on a powerful RK3399-M-L, highest 64-bit high-performance CPU. It is based on the Android 11.0 operating

system and is ideal for customization. They are equipped with onboard Wi-fi, USB-OTG, TF/SIM, LAN, COM, Audio I/O, HDMI, 2-pin connector for power supply The WebPanels are available in display sizes from 7" to 23.8" with projected capacitive or without touch.

ORDER DETAILS



Function: 17" TFT LCD WebPanel, 24V DC power supply, 1280 x 1024 pixels, Android 11.0, IP65 compact fanless housing, dual-core Cortex-A72 1.8GHz + quad-core Cortex-A53 1.4GHz processor, Wi-fi
SKU/Order No.: SA-PanelIPC-17-00-00

Mechanical Dimensions

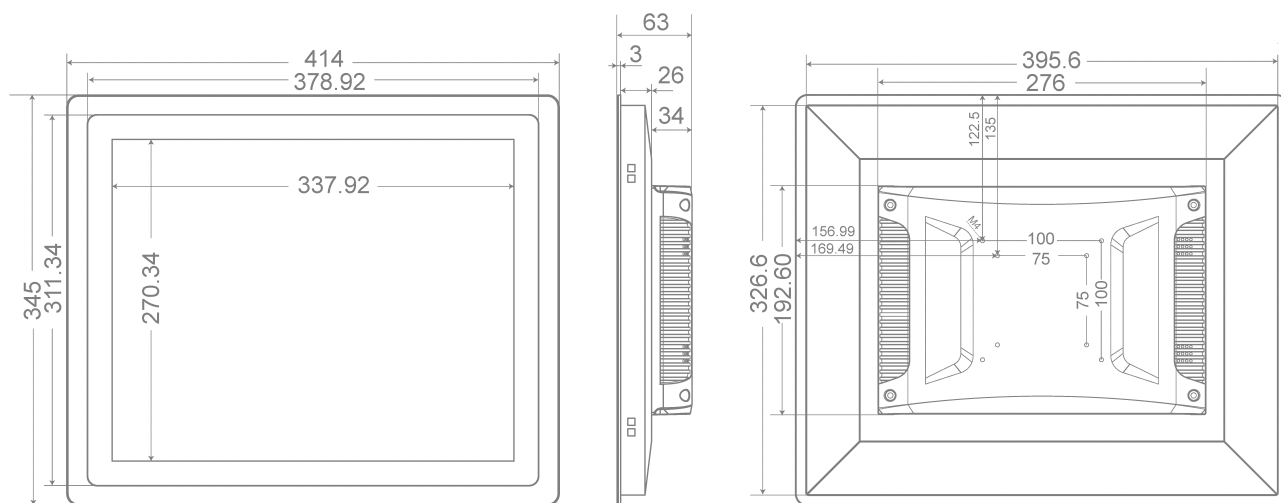

REV01_05062023

DATASHEET

PANEL-PC-17-A

Technical Data

Dimensions

Width (mm)	414
Height (mm)	345
Depth (mm)	63

Certification

Certification	FCC, CE
---------------	---------

Ambient Condition

Operating Humidity (non-condensing)	5 ... 80%
Storage Humidity (non-condensing)	5 ... 80%
Ambient Temperature (storage/transport)	-40 ... 85°C
Ambient Temperature (operating)	-10 ... 60°C

Mechanical Data

Housing	Aluminum alloy
Bezel Thickness	3mm

Standards and Regulations

In Compliance With	IP65
--------------------	------

Input Data

Power Consumption (max.)	≤30W; 1.53A @ 12V (18.4W); 1.8A @ 12V (21.6W)
Ports	2-pin terminal: 24V DC, 1*SIM card slot, 1*TF/SD card slot, 1*HDMI,1*RJ-45 network interface, 1*3.5mm Audio output interface, 2*com (Serial port)

Interface

USB Ports	2, 1*mini USB port for re-flash/upgrading firmware
-----------	--

Display Features

Active Area (mm)	337.92 × 270.336mm
Aspect Ratio	4:3
Contrast	1000:01:00
Display colors	16.7M (8-bit)
Display Size	17"
View angle	80/80/80/70
Luminance	300 ... 1000 nits
Panel Type	Industrial A grade LCD with LED backlight
Resolution	1280x1024
Response time	5ms
Touch Screen	Default with 10-point capacitive touch
Touch Screen Surface Hardness	7 Mohs
Touch Screen Transparency	90% (±3%)

System Hardware

Processor	RK3399-M-L, Highest 64-bit high-performance CPU, 1.8 GHz
OS Support	Android 11
Memory	4GB

IEEE Standards

IEEE 802-11A	Wi-Fi 2
IEEE 802-11B	Wi-Fi 1
IEEE 802-11G	Wi-Fi 3
IEEE 802.11N	Wi-Fi 4
IEEE 802.15	Bluetooth 5.0